

VORTEX

- Filthy water
- Domestic use
- Civil use



PERFORMANCE RANGE

- Flow rate up to **650 l/min** (39 m³/h)
- Head up to **14 m**

APPLICATION LIMITS

- **10 m** maximum immersion depth (with a sufficiently long power cable)
- Maximum liquid temperature **+40 °C**
- Passage of solids:
 - up to **Ø 40 mm** for TITAN /35
 - up to **Ø 50 mm** for TITAN /45
- Minimum immersion depth for continuous service:
 - **280 mm** for TITAN /35
 - **300 mm** for TITAN /45

CONSTRUCTION AND SAFETY STANDARDS

- Power cable
- Float switch for single-phase versions

EN 60335-1
IEC 60335-1
CEI 61-150

EN 60034-1
IEC 60034-1
CEI 2-3



CHARACTERISTIC CURVES AND PERFORMANCE DATA

50 Hz | n= 2900 min⁻¹

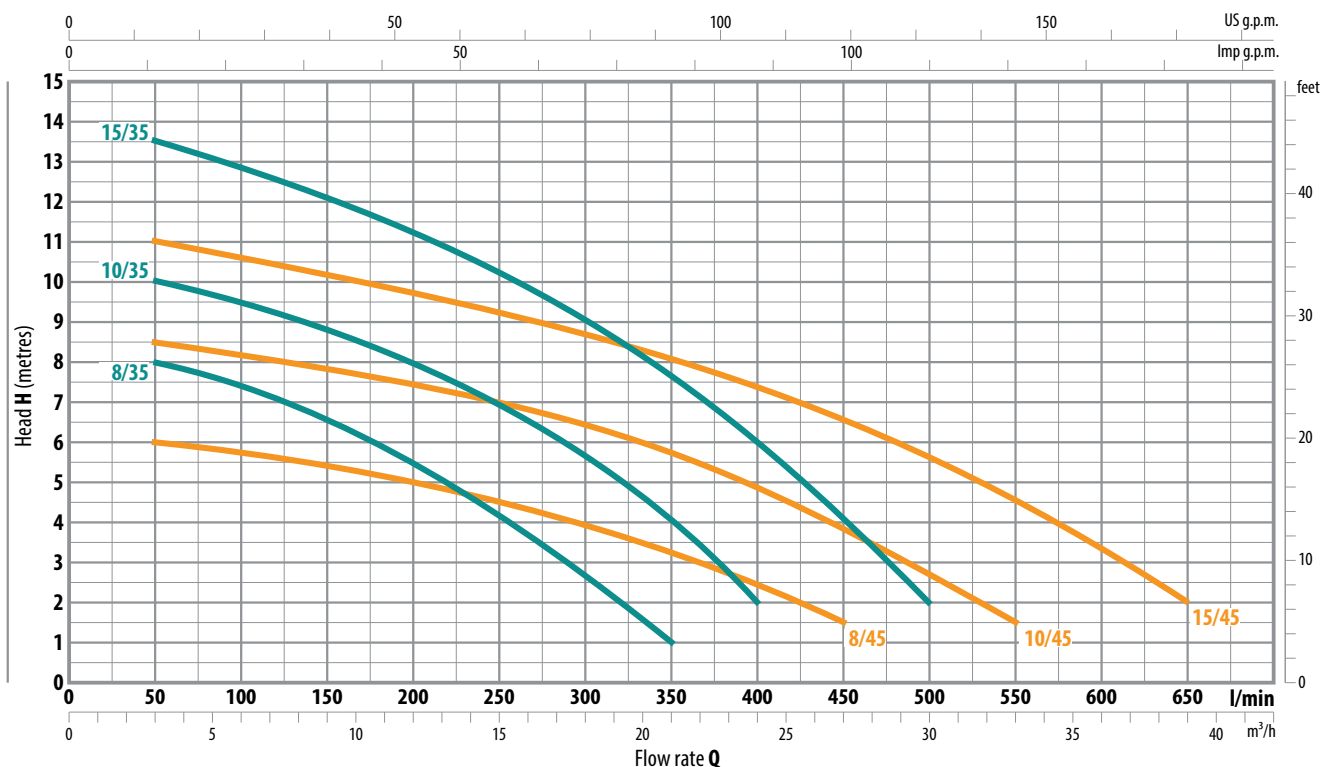

MODEL		POWER (P ₂)		Q	Flow rate													
Single-phase	Three-phase	kW	HP		0	3	6	12	18	21	24	27	30	33	36	39		
TITAN 8/35M	TITAN 8/35	0.55	0.75	H metres	9	8	7.5	5.5	2.7	1								
TITAN 10/35M	TITAN 10/35	0.75	1		11	10	9.5	8	5.7	4	2							
TITAN 15/35M	TITAN 15/35	1.1	1.5		14	13.5	12.8	11.2	9	7.7	6	4	2					
TITAN 8/45M	TITAN 8/45	0.55	0.75		6.5	6	5.8	5	4	3.3	2.5	1.5						
TITAN 10/45M	TITAN 10/45	0.75	1		9	8.5	8.2	7.5	6.5	5.8	5	3.8	2.5	1.5				
TITAN 15/45M	TITAN 15/45	1.1	1.5		11.5	11	10.5	9.8	8.7	8	7.5	6.5	5.5	4.5	3.5	2		

Q = Flow rate
H = Total manometric head

Tolerance of characteristic curves in compliance with EN ISO 9906 Grade 3B.

INSTALLATION AND USE

TITAN series pumps, made from heavy gauge cast iron offering exceptional sturdiness and abrasion resistance, come equipped with a VORTEX impeller and are therefore suitable for draining waste water containing suspended solids, filthy water and mixed with mud.

DIMENSIONS AND WEIGHT

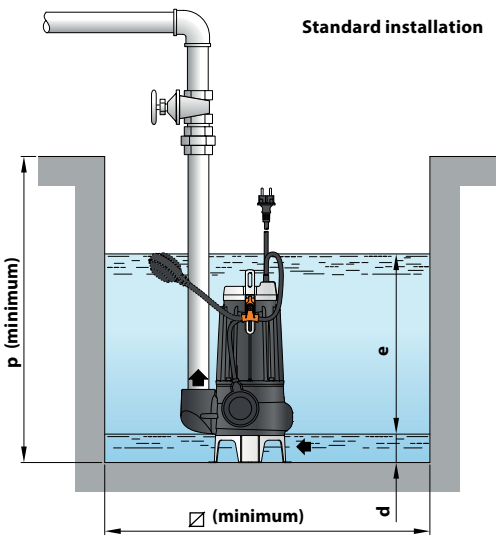
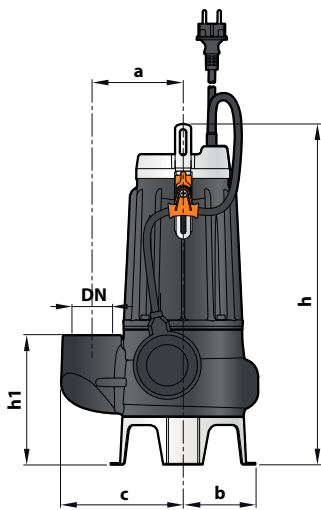

CONSTRUCTION CHARACTERISTICS

PUMP BODY	Cast iron with an Epoxy Electro Coating treatment, with threaded port in compliance with ISO 228/1
IMPELLER	Stainless steel AISI 304 VORTEX type
MOTOR SHAFT	Stainless steel AISI 431
SHAFT WITH DOUBLE MECHANICAL SEAL SEPARATED BY AN OIL CHAMBER	Motor side: Silicon carbide - Graphite - NBR Pump side: Silicon carbide - Silicon carbide - NBR
POWER CABLE	H07 RN-F type 10 m long power cable (with Schuko plug for single-phase versions only)

MODEL		PORT DN	Passage of solids	DIMENSIONS mm									kg	
Single-phase	Three-phase			a	b	c	h	h1	d	e	p	Ø	1~	3~
TITAN 8/35M	TITAN 8/35	1½"	Ø 40 mm	115	95	148	388	139	50	variable	500	500	17.0	16.7
TITAN 10/35M	TITAN 10/35						403						17.8	16.7
TITAN 15/35M	TITAN 15/35					17.5	17.2							
TITAN 8/45M	TITAN 8/45	2"	Ø 50 mm	115	95	155	413	164	60	variable	500	500	18.3	17.2
TITAN 10/45M	TITAN 10/45						428						18.3	17.2
TITAN 15/45M	TITAN 15/45					19.9	18.9							

ABSORPTION

MODEL	VOLTAGE		
	230 V	240 V	110 V
Single-phase	230 V	240 V	110 V
TITAN 8/35M	3.5 A	3.4 A	7.0 A
TITAN 10/35M	4.8 A	4.6 A	9.6 A
TITAN 15/35M	7.4 A	7.1 A	-
TITAN 8/45M	3.7 A	3.5 A	7.4 A
TITAN 10/45M	5.0 A	4.8 A	10.0 A
TITAN 15/45M	7.1 A	6.8 A	-

MODEL	VOLTAGE			
	230 V	400 V	240 V	415 V
Three-phase	230 V	400 V	240 V	415 V
TITAN 8/35	3.0 A	1.7 A	2.9 A	1.65 A
TITAN 10/35	3.5 A	2.0 A	3.4 A	1.95 A
TITAN 15/35	5.2 A	3.0 A	5.0 A	2.9 A
TITAN 8/45	3.2 A	1.8 A	3.1 A	1.75 A
TITAN 10/45	3.5 A	2.0 A	3.4 A	1.95 A
TITAN 15/45	5.2 A	3.0 A	5.0 A	2.9 A

PALLETIZATION

MODEL		GROUPAGE n. pumps	CONTAINER n. pumps
Single-phase	Three-phase		
TITAN 8/35M	TITAN 8/35	60	80
TITAN 10/35M	TITAN 10/35	60	80
TITAN 15/35M	TITAN 15/35	60	80
TITAN 8/45M	TITAN 8/45	54	72
TITAN 10/45M	TITAN 10/45	54	72
TITAN 15/45M	TITAN 15/45	54	72