

RANGER MC

SUBMERSIBLE PUMPS



DOUBLE-CHANNEL

-  Filthy water
-  Domestic use
-  Civil use
-  Industrial use



PERFORMANCE RANGE

- Flow rate up to **750 l/min** (45 m³/h)
- Head up to **15 m**

APPLICATION LIMITS

- **5 m** maximum immersion depth (with a sufficiently long power cable)
- Maximum liquid temperature **+40 °C**
- Passage of suspended solids up to **Ø 50 mm**
- Minimum immersion depth for continuous service: **300 mm**

CONSTRUCTION AND SAFETY STANDARDS

The pumps are complete with:

- power cable
- float switch for single-phase versions

EN 60335-1
IEC 60335-1
CEI 61-150

EN 60034-1
IEC 60034-1
CEI 2-3



CHARACTERISTIC CURVES AND PERFORMANCE DATA

50 Hz | n=2900 min⁻¹

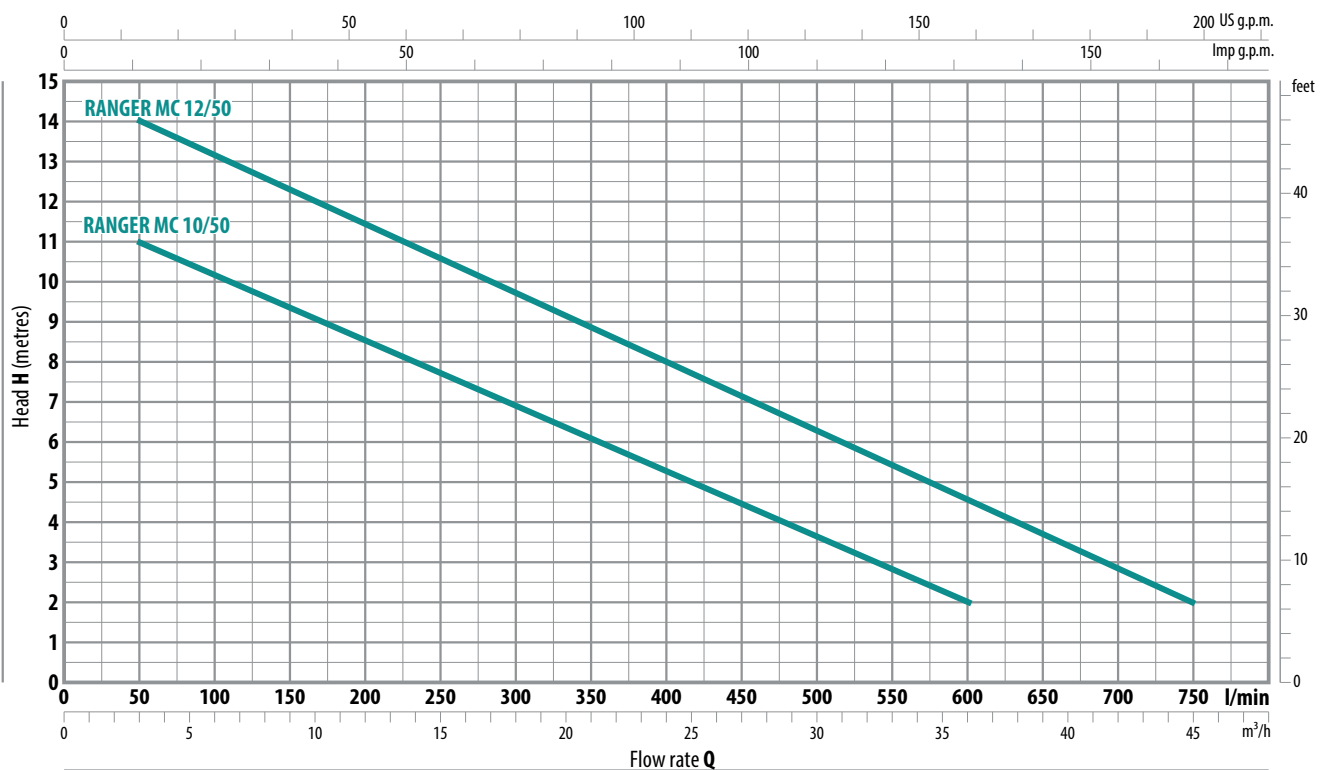

MODEL		POWER (P ₂)		Q	Flow rate									
Single-phase	Three-phase	kW	HP		0	50	100	200	300	400	500	600	700	750
RANGER MC 10/50M	RANGER MC 10/50	0.75	1	H metres	12	11	10	8.5	7	5	3.6	2		
RANGER MC 12/50M	RANGER MC 12/50	1.1	1.5		15	14	13	11.5	9.7	8	6.3	4.6	2.9	2

Q = Flow rate
H = Total manometric head

Tolerance of characteristic curves in compliance with EN ISO 9906 Grade 3B.

INSTALLATION AND USE

RANGER MC submersible pumps are suitable for draining dirty and filthy water in domestic and civil applications. They come equipped with a DOUBLE-CHANNEL stainless steel impeller and are capable of pumping liquids containing short fibred suspended solids up to Ø 50 mm.

They are ideal for pumping sewage, waste water, surface water and water mixed with mud in locations such as blocks of flats and detached houses.

These pumps distinguish themselves for their reliability, which can be best appreciated under automatic operating conditions in fixed installations.

CONSTRUCTION CHARACTERISTICS

PUMP BODY	Cast iron with an Epoxy Electro Coating treatment, with threaded port in compliance with ISO 228/1
IMPELLER	Precision cast stainless steel AISI 304 DOUBLE-CHANNEL type
MOTOR SHAFT	Stainless steel AISI 431
SHAFT WITH DOUBLE MECHANICAL SEAL SEPARATED BY AN OIL CHAMBER	Motor side: Silicon carbide - Graphite - NBR Pump side: Silicon carbide - Silicon carbide - NBR
POWER CABLE	H07 RN-F type 5 m for RANGER 10/50 10 m for RANGER 12/50 (with Schuko plug for single-phase versions only)

DIMENSIONS AND WEIGHT

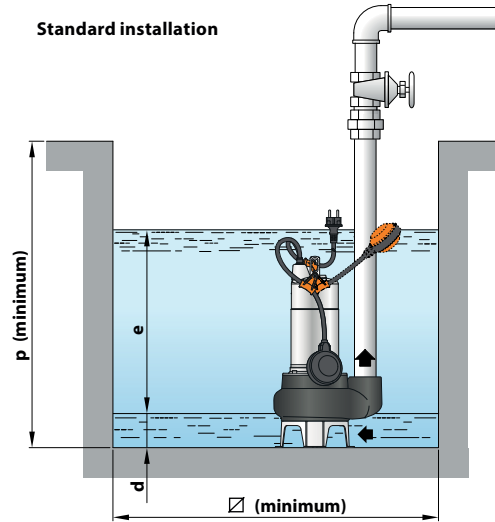
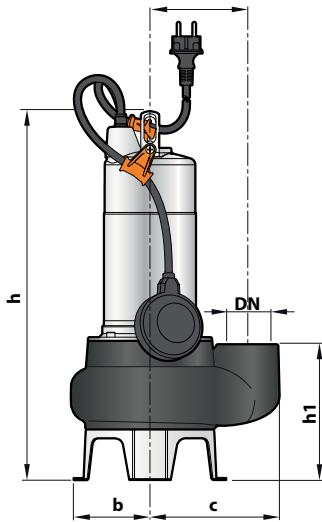

MODEL		PORT DN	Passage of solids	DIMENSIONS mm								kg		
Single-phase	Three-phase			a	b	c	h	h1	d	e	p	Ø	1~	3~
RANGER MC 10/50M	RANGER MC 10/50	2"	Ø 50 mm	115	95	155	431	164	60	variable	500	500	14.9	13.8
RANGER MC 12/50M	RANGER MC 12/50						446						16.5	15.5

ABSORPTION

MODEL	VOLTAGE		
	230 V	240 V	110 V
Single-phase			
RANGER MC 10/50M	5.0 A	4.8 A	10.0 A
RANGER MC 12/50M	8.2 A	7.9 A	-

MODEL	VOLTAGE			
	230 V	400 V	240 V	415 V
Three-phase				
RANGER MC 10/50	3.7 A	2.1 A	3.5 A	2.0 A
RANGER MC 12/50	5.6 A	3.2 A	5.4 A	3.1 A

PALLETIZATION

MODEL		GROUPAGE n. pumps	CONTAINER n. pumps
Single-phase	Three-phase		
RANGER MC 10/50M	RANGER MC 10/50	54	72
RANGER MC 12/50M	RANGER MC 12/50	54	72