

Model No. DUH523 520MM CORDLESS HEDGE TRIMMER

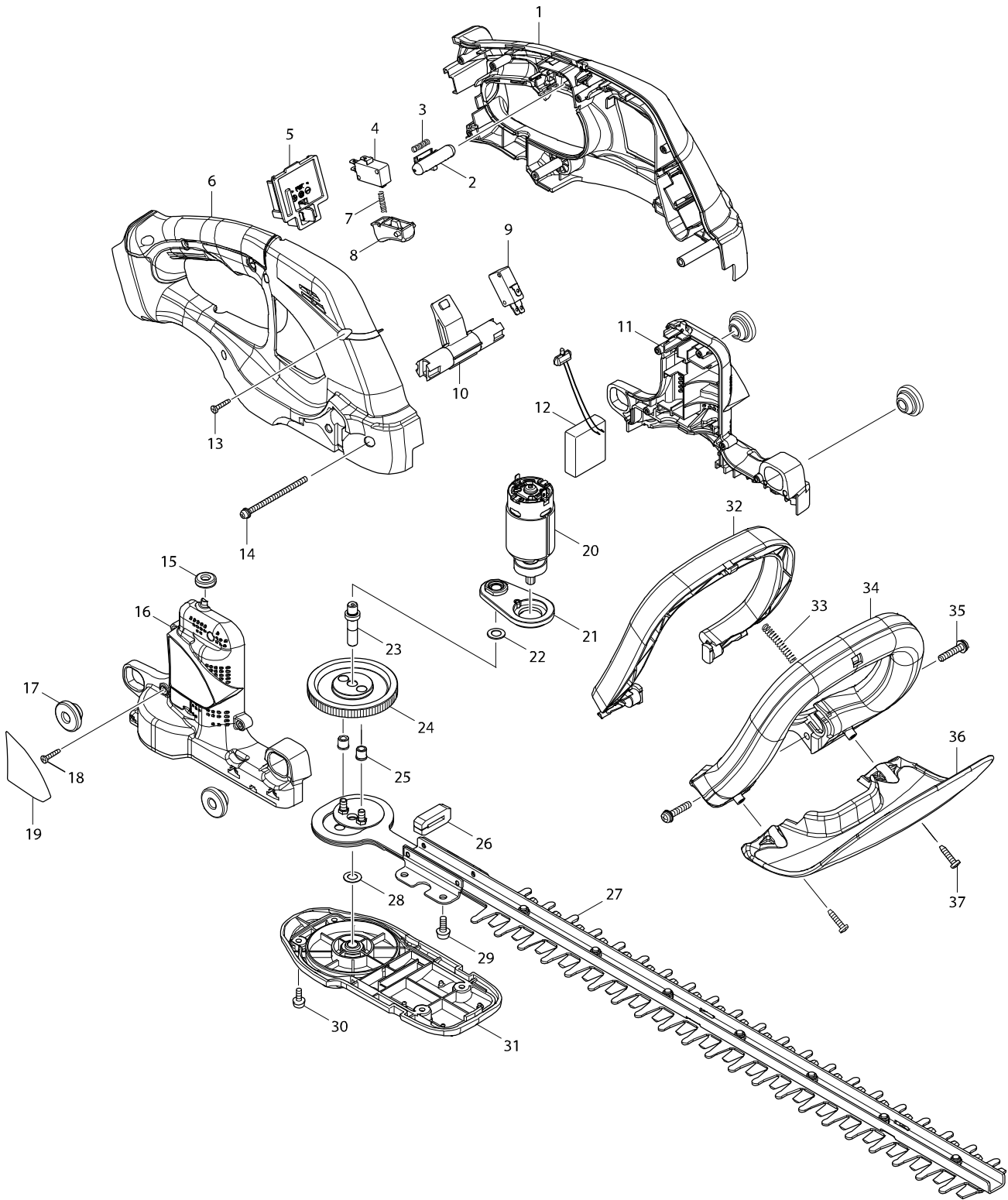

Model No. DUH523 520MM CORDLESS HEDGE TRIMMER

Item	Parts No.	Description	I/C	Qty	N/O	Opt. 1	Opt. 2	Note
001	187286-4	HANDLE SET		1				
D10		INC. 6						
002	452438-9	LOCK OFF BUTTON		1				
003	231473-8	COMPRESSION SPRING 4		1				
004	651852-8	SWITCH V-15-1A5		1				
005	643852-2	TERMINAL		1				
006	187286-4	HANDLE SET		1				
D10		INC. 1						
007	231473-8	COMPRESSION SPRING 4		1				
008	417564-1	SWITCH LEVER		1				
009	651852-8	SWITCH V-15-1A5		1				
010	452681-0	SWITCH ARM		1				
011	187285-6	MOTOR HOUSING SET		1				
D10		INC. 16						
012	638967-8	CONTROLLER UNIT		1				
013	266429-2	TAPPING SCREW 3X16		6				
014	911193-7	PAN HEAD SCREW M4X65		1				
015	424195-9	RUBBER RING 6		1				
016	187285-6	MOTOR HOUSING SET		1				
D10		INC. 11						
017	424394-3	RUBBER RING 8		4				
018	266429-2	TAPPING SCREW 3X16		5				
019	815U45-9	DUH523 NAME PLATE		1				
020	629930-2	DC MOTOR		1				
021	141211-9	BEARING BOX COMPLETE		1				
022	253215-0	FLAT WASHER 8		1				
023	326034-8	SPINDLE		1				
024	227281-3	SPUR GEAR 93		1				
025	262570-9	NYLON SLEEVE 5		2				
026	423417-4	DUST GUARD		1				
027	195769-0	SHEAR BLADE COMPLETE SET		1				
C10	188605-7	OIL VESSEL SET		1				
C20	262570-9	NYLON SLEEVE 5		2				
028	253215-0	FLAT WASHER 8		1				
029	911218-7	PAN HEAD SCREW M5X14		4				
030	911113-1	PAN HEAD SCREW M4X10 WITH WR		4				
031	453317-4	UNDER COVER		1				
032	452678-9	SWITCH LEVER B		1				
033	234261-2	COMPLESSION SPRING 5		1				
034	452682-8	FRONT GRIP		1				
035	911243-8	PAN HEAD SCREW M5X25		2				
036	453316-6	PROTECTOR		1				
037	265995-6	TAPPING SCREW 4X18		2				
A01	452685-2	BLADE COVER		1				
A02D	***DC18RC	DC18RC FAST CHARGER		1				
A02E	***DC18RC	DC18RC FAST CHARGER		1				
A03D	194204-5	BATTERY BL1830 SET		1	*			
A03-1D	194204-5	BATTERY BL1830 SET	O	1	*			

