



# Charger starter device accumulators PREMIUM-HD

## USER MANUAL

Thank you for choosing the Jump Starter! Always follow basic safety precautions when using electrical appliances. Read all instructions carefully, please keep this instruction manual for easy reference.

**Model: 0503BCINVERTER**



e-mail: [info@valerii.com](mailto:info@valerii.com) [www.valerii.com](http://www.valerii.com)  
Сервиз: тел. 02/ 942 34 70 (национален)

Централен офис: София 1517

кв. "Сухата река" бул. "Ботевградско шосе" 44

тел.: 02/ 942 34 00, факс.: 02/ 945 4634

GSM 0889/ 444 991

Пловдив, с.Труд 4199

ул. "Строевско шосе" 3

тел./факс 032/ 953 666

GSM 0885/ 808 003

Варна 9000, кв. "Владиславово"

бул. "Атанас Москов" 13

тел.: 052/ 504 514

GSM 0885/ 808 004

София 2227, кв."Божурище"

бул. "Европа" 180, склад 33

тел.: 02/ 925 22 37

GSM 0889/ 334 692

Проверил: Р.Ч./16.10.2016г.



**A.PRODUCT LAYOUT:**

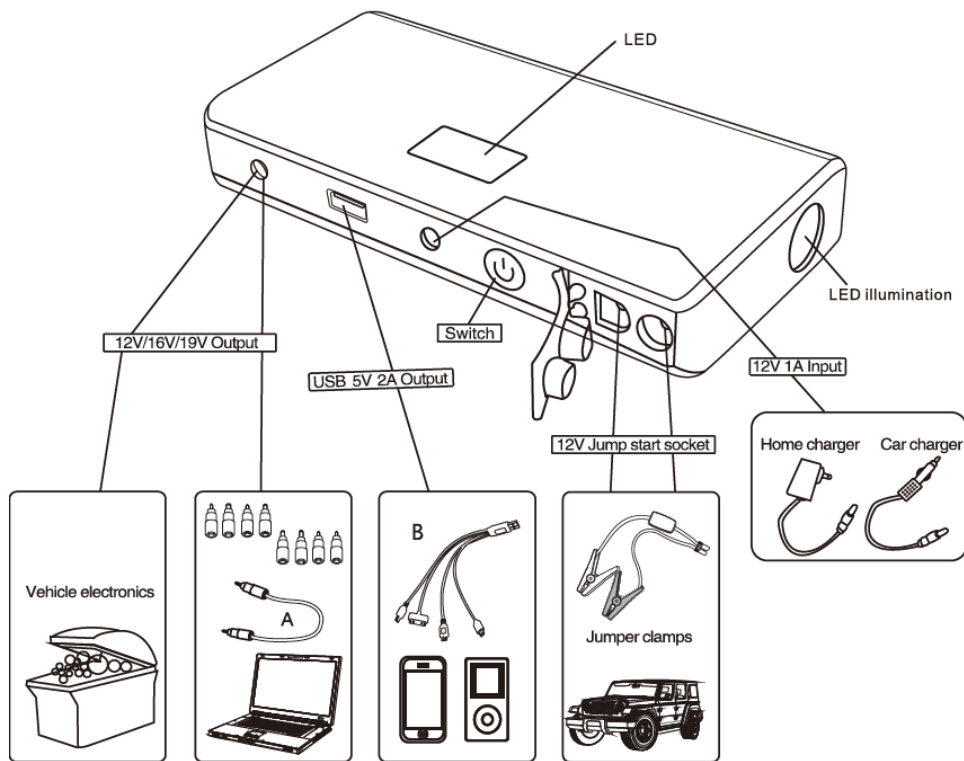

①



e-mail: [info@valerii.com](mailto:info@valerii.com) [www.valerii.com](http://www.valerii.com)  
Сервиз: тел. 02/ 942 34 70 (национален)

Централен офис: София 1517  
кв. "Сухата река" бул. "Ботевградско шосе" 44  
тел.: 02/ 942 34 00, факс.: 02/ 945 4634  
GSM 0889/ 444 991

Пловдив, с.Труд 4199  
ул. "Строевско шосе" 3  
тел./факс 032/ 953 666  
GSM 0885/ 808 003

Варна 9000, кв. "Владиславово"  
бул. "Атанас Москов" 13  
тел.: 052/ 504 514  
GSM 0885/ 808 004

София 2227, кв."Божурище"  
бул. "Европа" 180, склад 33  
тел.: 02/ 925 22 37  
GSM 0889/ 334 692

Проверил: Р.Ч./16.10.2016г.



## B. OPERATION GUIDANCE

### Indicator

Press the switch to check the storage level of Jump Starter

### Jump Starter Charging Instruction:

- 1.Plug the home adaptor into the universal socket.
  - 2.Connect 12V 1A input port of Jump Starter to the other end of home adaptor.
- Or
- 1.Plug the car adaptor into the socket of cigarette lighter.
  - 2.Connect 12V 1A input port of Jump Starter to the other end of car adaptor.

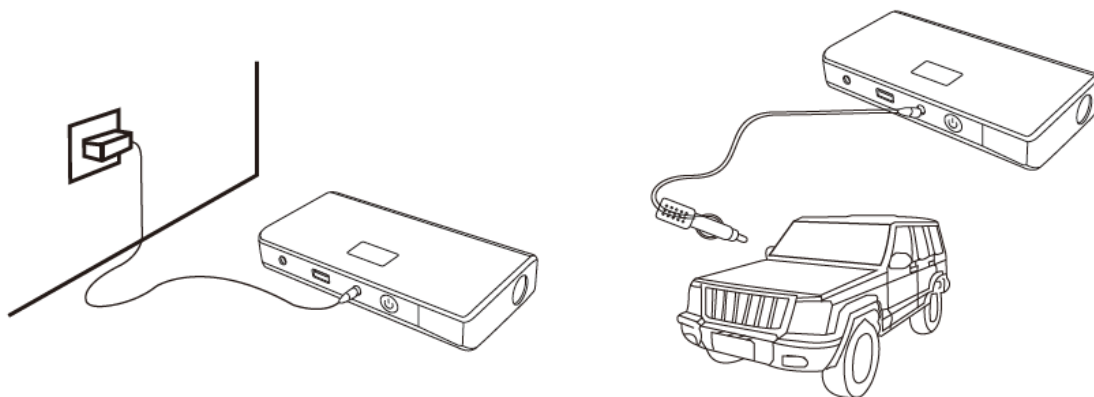

### Jump start 12V vehicle instruction:

- 1.Make sure the remaining power is not less than 70
- 2.Connect the RED clamp to the vehicle's battery positive (+) terminal and connect the BLACK clamp to the vehicle's battery negative (-) terminal.
- 3.Plug the cord of jumper cable into the jump start socket.

②



e-mail: [info@valerii.com](mailto:info@valerii.com) [www.valerii.com](http://www.valerii.com)  
Сервиз: тел. 02/ 942 34 70 (национален)

Централен офис: София 1517

кв. "Сухата река" бул. "Ботевградско шосе" 44

тел.: 02/ 942 34 00, факс.: 02/ 945 4634

GSM 0889/ 444 991

Пловдив, с.Труд 4199

ул. "Строевско шосе" 3

тел./факс 032/ 953 666

GSM 0885/ 808 003

Варна 9000, кв. "Владиславово"

бул. "Атанас Москов" 13

тел.: 052/ 504 514

GSM 0885/ 808 004

София 2227, кв."Божурище"

бул. "Европа" 180, склад 33

тел.: 02/ 925 22 37

GSM 0889/ 334 692

Проверил: Р.Ч./16.10.2016г.



4. Start the vehicle

5. When the vehicle is started, remove jumper cable from Jump Starter and disconnect red and black clamps to the vehicle battery terminals within 30 seconds.

6. Leave the vehicle's engine running

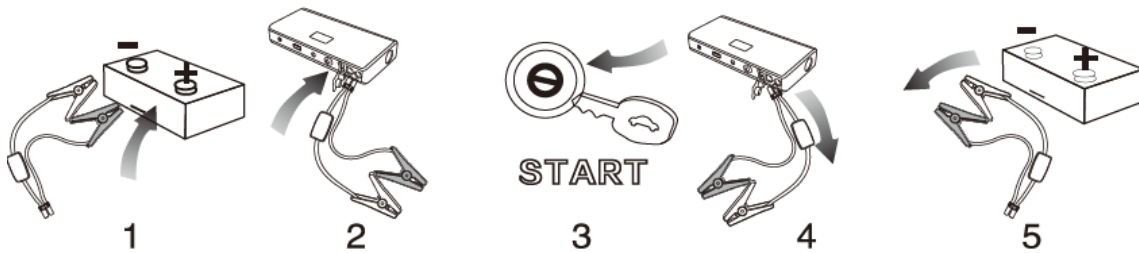

### Charging Cell Phone or Tablet Instruction:

1. Plug the switch cable B to USB 5V 2A output port.

2. Select appropriate connector for your cell phone or tablet and connect it to any of them, Jump Starter can identify and charge the electronic device automatically.

3. Press the switch button to charge. The indicators will be on when the device is charging.

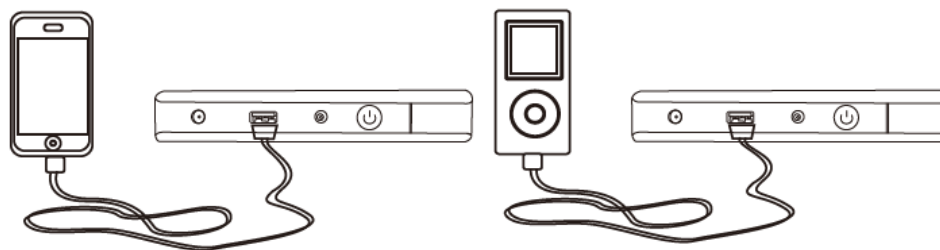

### Charging/power supply for 16V/19V laptop:

1. Plug the switch cable A to 12V/16V/19V output port.

2. Select appropriate connector of your laptop and connect it to switch cable A.

3. Press the switch button and choose the correct output voltage to charge the laptop.

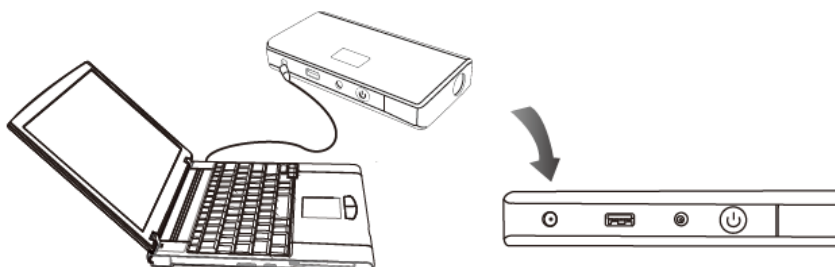

3



**Power supply for 12V vehicle electronics:**

1. Connect the switch cable A to 12V/16V/19V output port.
2. Connect the optional switch cable to 12V vehicle electronics.
3. Press the switch button and choose the correct output voltage and power sourcing the electronics.

**LED flash light**

Press the switch 3 seconds to start the LED flash light.

There are 4 modes of LED light appear in order(normal.strobe.SOS .off)if you press slightly.

**C.PARTS LIST:**

#	Parts Name	Quantity	#	Parts Name	Quantity
1	Host	1	5	Home adaptor	1
2	Switch cable A	1	6	Car adaptor	1
3	Notebook connectors	8	7	User Manual	1
4	Jumper cable with clamps	1	8	USB Cable	1

**D. TECHNICAL SPECIFICATIONS:**

Size: 160*75*28mm
Weight: 430g
Output: 5V --- 2A,(12V,16V,19V)/3.5A
Input: 12V --- 1A
Full charging time: 5hours
Starting current: 200A
Peak current: 400A
Operating temperature: -20°C-60°C

**E. FAQ:**

Q. How to turn off this appliance?

A. This appliance will power off automatically when no load or charging is complete

④



e-mail: [info@valerii.com](mailto:info@valerii.com) [www.valerii.com](http://www.valerii.com)

Сервиз:тел. 02/ 942 34 70 (национален)

Централен офис: София 1517

кв. "Сухата река" бул. "Ботевградско шосе" 44  
тел.: 02/ 942 34 00, факс.: 02/ 945 4634

GSM 0889/ 444 991

Пловдив, с.Труд 4199

ул. "Строевско шосе" 3  
тел./факс 032/ 953 666

GSM 0885/ 808 003

Варна 9000, кв. "Владиславово"

бул. "Атанас Москов" 13  
тел.: 052/ 504 514

GSM 0885/ 808 004

София 2227, кв."Божурище"

бул. "Европа" 180, склад 33  
тел.: 02/ 925 22 37

GSM 0889/ 334 692



Q.How many times can this appliance charge for my cell phone?

A.6 times for Iphone 4 mobile phone.

Q.How long will this appliance take to charge my mobile phone full?

A.Approx. 1hour

Q.How long will this appliance on a full charge take to supply the Notebook?

A.2–3 hours.

Q.How man times can this appliance on a full charge to the start the vehicle?

A.Approx. 20 times.

Q.How long will the power of battery of this appliance remain?

A.3–6 months,however,we suggest to recharge it every 3 months.

## F. TROUBLE SHOOTING:

Finding	Cause	Remedies
Jump Starter is still not full charged while its LED shows 99	Actual power remaining is about 60% but it appears 99%	Unplug the adaptor and plug it again
No response when pressing the swithch button.	Low voltage protection of Jump Starter is actrated	Plug the adaptor into the 12V 1A input port to activate.
Jump Starter is a bit hot when charging for Notebook.	The charging current is a bit high(3.5A)	Remove the battery from the notebook or charge the notebook after a 5 minutes break.

## G. TOXIC AND HARMFUL SUBSTANCES:

Composition and amount of toxic and harmful substance in Jump Starter					
Pb	Hg	Cd	Cr(Vi)	PBB	PBDE
0	0	0	0	0	0
0:Indicate all homogeneous materials's hazardous substances content are below the MCV limit specified in the standard 2002/95/EC (RoHS)					

5



e-mail: [info@valerii.com](mailto:info@valerii.com) [www.valerii.com](http://www.valerii.com)  
Сервиз:тел. 02/ 942 34 70 (национален)

Централен офис: София 1517

кв. "Сухата река" бул. "Ботевградско шосе" 44

тел.: 02/ 942 34 00, факс.: 02/ 945 4634

GSM 0889/ 444 991

Пловдив, с.Труд 4199

ул. "Строевско шосе" 3

тел./факс 032/ 953 666

GSM 0885/ 808 003

Варна 9000, кв. "Владиславово"

бул. "Атанас Москов" 13

тел.: 052/ 504 514

GSM 0885/ 808 004

София 2227, кв."Божурище"

бул. "Европа" 180, склад 33

тел.: 02/ 925 22 37

GSM 0889/ 334 692

Проверил: Р.Ч./16.10.2016г.



## H. Warning:

1. DO remove the product from the vehicle within 30s
2. DO NOT connect the two clamps. Otherwise, it may be dangerous!
3. DO NOT disassemble the host. Otherwise, it may be dangerous!



Always take care when using the appliance



This appliance is not intended for use by young or infirm persons without supervision



Do not use as a toy



Do not allow the appliance to become wet



Do not immerse the appliance in water



Do not operate the appliance in explosive atmospheres, such as in the presence of flammable liquids, gases or dust



Do not modify or disassemble Jump Starter. Only a repair technician may repair this unit



Do not expose the appliance to heat

Do not store in locations where the temperature may exceed 70°C



Charge only at ambient temperatures between -20°C-60°C



Charge only using the charger provided with the appliance



Under extreme conditions, battery leakage may occur. Carefully wipe the liquid off using a cloth and avoid skin contact when you notice liquid on the batteries. In case of skin or eye contact, rinse immediately with clean water and seek medical attention



At the end of their useful life, discard the appliance with due care for our environment

⑥



e-mail: [info@valerii.com](mailto:info@valerii.com) [www.valerii.com](http://www.valerii.com)

Сервиз: тел. 02/ 942 34 70 (национален)

Централен офис: София 1517

кв. "Сухата река" бул. "Ботевградско шосе" 44

тел.: 02/ 942 34 00, факс.: 02/ 945 4634

GSM 0889/ 444 991

Пловдив, с.Труд 4199

ул. "Строевско шосе" 3

тел./факс 032/ 953 666

GSM 0885/ 808 003

Варна 9000, кв. "Владиславово"

бул. "Атанас Москов" 13

тел.: 052/ 504 514

GSM 0885/ 808 004

София 2227, кв."Божурище"

бул. "Европа" 180, склад 33

тел.: 02/ 925 22 37

GSM 0889/ 334 692

Проверил: Р.Ч./16.10.2016г.



## I. WARRANTY INFORMATION:

1. We offer a limited warranty for this product against any defects in material and workmanship for a period of **36** months from the date of purchase by the end user/consumer. The conditions of the warranty are as follows

2. The warranty is only valid upon presentation of the original receipt (from dealer/retailer) by the original purchaser with the product to be repaired or replaced

3. The warranty is invalid if the label of purchase date is removed or torn

4. The warranty does not cover damage or product failure resulting from normal wear and tear, physical abuse, improper installation, misuse, modification or repairs by unauthorized third parties

5. We do not assume responsibility for any loss or damage incurred during shipment or as a result of a force majeure

6. We are not liable for any incidental or consequential damages arising from the use or misuse of the product

7. All warranty claims are limited to repair or replacement of the defective product and at the sole discretion of us

8. If we repair or replace the product, the product will be covered for the remaining time of the original warranty period. Repair or replacement may involve the use of reconditioned units which are equivalent in function. Replaced part or product becomes the property of us.

9. Consumable components are not covered by the warranty.



Overcharge and Overdischarge Protection



Fuse Protection



Against-reverse Plug

Applied Standard: GB/T 18287-2000



e-mail: [info@valerii.com](mailto:info@valerii.com) [www.valerii.com](http://www.valerii.com)

Сервиз: тел. 02/ 942 34 70 (национален)

Централен офис: София 1517

кв. "Сухата река" бул. "Ботевградско шосе" 44

тел.: 02/ 942 34 00, факс.: 02/ 945 4634

GSM 0889/ 444 991

Пловдив, с.Труд 4199

ул. "Строевско шосе" 3

тел./факс 032/ 953 666

GSM 0885/ 808 003

Варна 9000, кв. "Владиславово"

бул. "Атанас Москов" 13

тел.: 052/ 504 514

GSM 0885/ 808 004

София 2227, кв. "Божурище"

бул. "Европа" 180, склад 33

тел.: 02/ 925 22 37

GSM 0889/ 334 692





# Baterii dispozitiv încărcător pentru pornire PREMIUM-HD

Vă mulțumim că ați ales sursa noastră externă de aprindere!  
Respectați întotdeauna măsurile de siguranță atunci când utilizați aparate  
electrice. Citiți cu atenție toate instrucțiunile, vă rugăm să păstrați acest  
manual pentru referință ușoară.

Model: **0503BCINVERTER**

Prezentare generală a produsului:

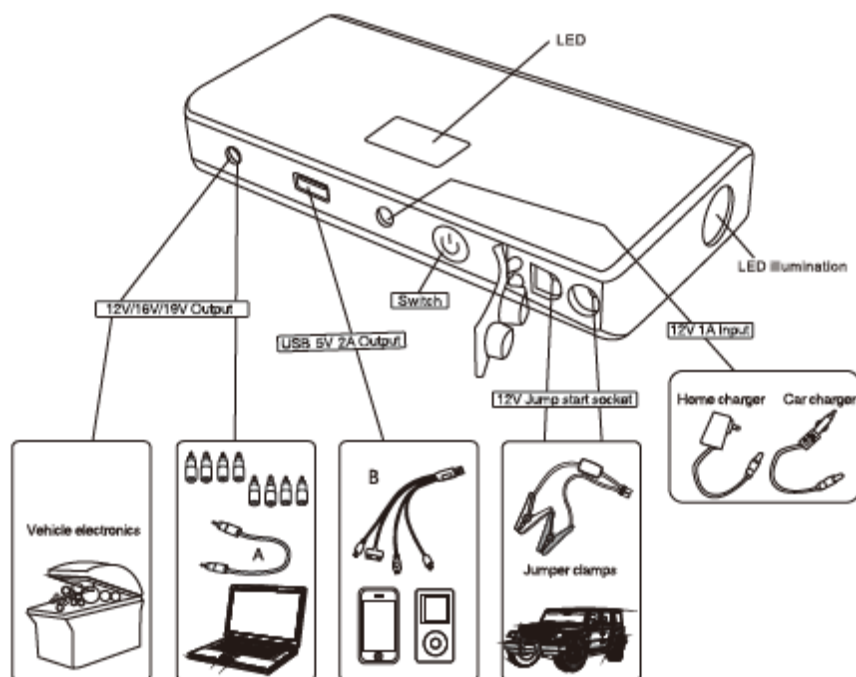

e-mail: [info@valerii.com](mailto:info@valerii.com) [www.valerii.com](http://www.valerii.com)  
Сервиз: тел. 02/ 942 34 70 (национален)

Централен офис: София 1517  
кв. "Сухата река" бул. "Ботевградско шосе" 44  
тел.: 02/ 942 34 00, факс.: 02/ 945 4634  
GSM 0889/ 444 991

Пловдив, с.Труд 4199  
ул. "Строевско шосе" 3  
тел./факс 032/ 953 666  
GSM 0885/ 808 003

Варна 9000, кв. "Владиславово"  
бул. "Атанас Москов" 13  
тел.: 052/ 504 514  
GSM 0885/ 808 004

София 2227, кв."Божурище"  
бул. "Европа" 180, склад 33  
тел.: 02/ 925 22 37  
GSM 0889/ 334 692

Проверил: Р.Ч./16.10.2016г.



## A. B. INSTRUCȚIUNI DE UTILIZARE

Indicator

Apăsați întrerupătorul pentru a verifica nivelul sursei externe de aprindere

InstrucȚiuni de încărcarea sursei de aprindere externă:

1. Conectați adaptorul de acasă la priză universală
2. Conectați portul de intrare de 12 V 1 A în sursa de aprindere externă la celălalt capăt al adaptorului de acasă.

sau

1. Conectați adaptorul de autovehicul la priza de bricheta.
2. Conectați portul de intrare de 12 V 1 A în sursa de aprindere externă la celălalt capăt al adaptorului auto.

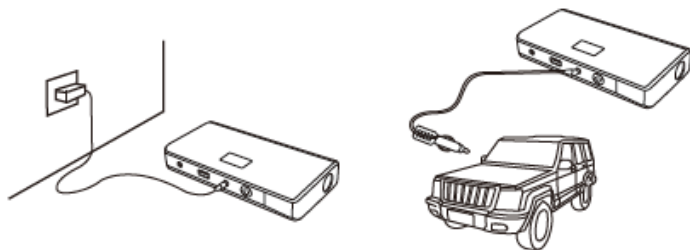

InstrucȚiuni de sursă externă de aprindere auto de 12 V:

1. Asigurați-vă că puterea rămasă este nu mai puțin de 70
2. Conectați clema ROȘIE la borna pozitivă a bateriei și conectați clema NEAGRĂ la borna negativă a bateriei auto.
3. Conectați cablul de aprindere de la sursă externă la mufa sursei externe de aprindere.



e-mail: [info@valerii.com](mailto:info@valerii.com) [www.valerii.com](http://www.valerii.com)

Сервиз: тел. 02/ 942 34 70 (национален)

Централен офис: София 1517

кв. "Сухата река" бул. "Ботевградско шосе" 44

тел.: 02/ 942 34 00, факс.: 02/ 945 4634

GSM 0889/ 444 991

Пловдив, с.Труд 4199

ул. "Строевско шосе" 3

тел./факс 032/ 953 666

GSM 0885/ 808 003

Варна 9000, кв. "Владиславово"

бул. "Атанас Москов" 13

тел.: 052/ 504 514

GSM 0885/ 808 004

София 2227, кв. "Божурище"

бул. "Европа" 180, склад 33

тел.: 02/ 925 22 37

GSM 0889/ 334 692

Проверил: Р.Ч./16.10.2016г.



4. Porniți mașina

5. După ce ați pornit mașina, scoateți cablul de aprindere externă și deconectați bornele bateriei auto în termen de 30 de secunde.

6. Lăsați motorul vehiculului să funcționează



Instrucțiuni de încărcarea unui telefon mobil sau tabletă:

1. Conectați cablul de alimentare B la port extern USB 5 V 2 A.

2. Selectați duză corespunzătoare de telefonul mobil sau de tabletă și conectați-l la telefon sau tabletă, dispozitiv de aprindere extern poate identifica în mod automat și să încarcă dispozitivul electronic.

3. Apăsați întrerupătorul de încărcare. Atunci când dispozitivul se încarcă, indicatorii se aprind.

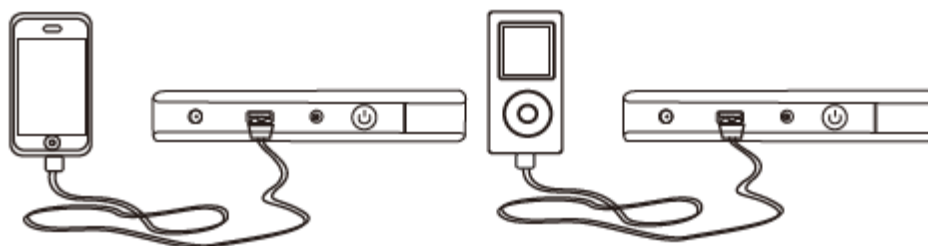

Încărcare/alimentare de laptop 16 V / 19 V:

1 Conectați cablul de alimentare la portul de ieșire 12 V / 16 V / 19 V.

2 Selectați duză corespunzătoare de laptopul d-ștră și conectați la cablul de alimentare A.

3 Apăsați întrerupătorul și selectați tensiunea de ieșire corespunzătoare pentru a încărca laptop.



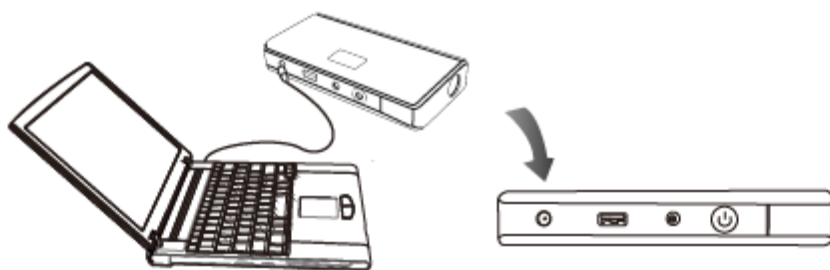

e-mail: [info@valerii.com](mailto:info@valerii.com) [www.valerii.com](http://www.valerii.com)  
Сервиз: тел. 02/ 942 34 70 (национален)

Централен офис: София 1517  
кв. "Сухата река" бул. "Ботевградско шосе" 44  
тел.: 02/ 942 34 00, факс.: 02/ 945 4634  
GSM 0889/ 444 991

Пловдив, с.Труд 4199  
ул. "Строевско шосе" 3  
тел./факс 032/ 953 666  
GSM 0885/ 808 003

Варна 9000, кв. "Владиславово"  
бул. "Атанас Москов" 13  
тел.: 052/ 504 514  
GSM 0885/ 808 004

София 2227, кв."Божурище"  
бул. "Европа" 180, склад 33  
тел.: 02/ 925 22 37  
GSM 0889/ 334 692

Проверил: Р.Ч./16.10.2016г.



Alimentarea cu energie de dispozitive electronice auto 12 V:

1. Conectați cablul de alimentare la portul de ieșire 12 V / 16 V / 19 V.
2. Conectați cablul de alimentare opțional la electronica auto 12 V
3. Apăsați întrerupătorul și selectați tensiune de ieșire corespunzătoare de alimentare cu energie electronică.

LED-uri de lumină intermitentă

Apăsați și țineți apăsat întrerupătorul timp de trei secunde pentru a porni LED-ul intermitent.

Dacă apăsați pe ușor, lumina LED are 4 moduri care alternează (lumină normală, stroboscopic, SOS, off).

## B. LISTĂ DE PIESE:

Nr.	Denumirea piesei	Cantitate	Nr.	Denumirea piesei	Cantitate
1	Unitatea principală	1	5	Adaptor de acasă	1
2	Cablul de alimentare A	1	6	Adaptor auto	1
3	Duze de laptop	8	7	Instrucțiunile de utilizare	1
4	Cablul de aprindere cu cleme	1	8	Cablu USB	1

## C. CARACTERISTICI TEHNICE:

CARACTERISTICI TEHNICE: 160 \* 75 \* 28 mm

Greutate 430 g

Ieșire: 5 V ~ 2 A, (12 V, 16 V, 19 V) / 3.5 A

Intrare:; 12 V= 1 A

Timp de încărcare: 5 ore

Curent de pornire: 200 A

Curentul de vârf: 400 A

Temperatura de lucru: -20°C - 60°C

## D. Întrebări frecvente

Q. Cum se deconectează dispozitivul acest?

A. Dispozitivul se va opri automat atunci când nu există nici o sarcină sau încărcarea este



e-mail: [info@valerii.com](mailto:info@valerii.com) [www.valerii.com](http://www.valerii.com)  
Сервиз: тел. 02/ 942 34 70 (национален)

Централен офис: София 1517  
кв. "Сухата река" бул. "Ботевградско шосе" 44  
тел.: 02/ 942 34 00, факс.: 02/ 945 4634  
GSM 0889/ 444 991

Пловдив, с.Труд 4199  
ул. "Строевско шосе" 3  
тел./факс 032/ 953 666  
GSM 0885/ 808 003

Варна 9000, кв. "Владиславово"  
бул. "Атанас Москов" 13  
тел.: 052/ 504 514  
GSM 0885/ 808 004

София 2227, кв."Божурище"  
бул. "Европа" 180, склад 33  
тел.: 02/ 925 22 37  
GSM 0889/ 334 692

Проверил: Р.Ч./16.10.2016г.



finalizată

Q. De câte ori pot încărca telefonul meu mobil cu acest aparat?

A. 6 ori Iphone și 4 ori telefonul mobil.

Q. Cât timp va dura încărcarea telefonului meu pe deplin cu dispozitivul acest.

A. Aproximativ 1 oră.

Q. Cât timp acest aparat poate alimenta un laptop la încărcare completă?

A. 2-3 ore.

Q. De câte ori acest aparat poate porni mașina mea la încărcare completă?

A. Aproximativ 20 ori.

Q. Cât timp ține sarcina electrică dispozitivului?

A. 3-6 luni, cu toate că vă sfătuim să-l reîncărcați la fiecare două luni.

## E. DEPANARE:

Manifestare	Cauza	Mod de depanare
Sursa de aprindere externă nu este complet încărcată, iar afișajul cu LED-uri arată 99	Capacitatea reziduală este de aproximativ 60%, iar arată 99%.	Deconectați adaptorul și conectați-l din nou
Nici un răspuns la apăsarea întreprătorului.	Este activată protecție minimă de tensiune sursei externe.	Introduceți adaptorul într-un port de intrare 12 V 1 A, pentru a activa.
Sursa externă se încălzește ușor în timp ce se încarcă laptop.	Puterea de încărcare este mare (3,5 A)	Scoateți bateria de la laptop sau încărcați laptop-ul după 5 minute de repaus.

## G. SUBSTANȚE TOXICE ȘI DĂUNĂTOARE:

Compoziția și cantitatea de substanțe toxice și nocive în sursa externă de aprindere

Pb	Hg	Cd	Cr(VI)	PBB	PBDE
0	0	0	0	0	0

0 0: indică faptul că conținutul de substanțe nocive în orice material omogen este mai mic decât limită MCV stabilită în standardul 2002/05 / CE (RoHS)



e-mail: [info@valerii.com](mailto:info@valerii.com) [www.valerii.com](http://www.valerii.com)

Сервиз: тел. 02/ 942 34 70 (национален)

Централен офис: София 1517

кв. "Сухата река" бул. "Ботевградско шосе" 44

тел.: 02/ 942 34 00, факс.: 02/ 945 4634

GSM 0889/ 444 991

Пловдив, с.Труд 4199

ул. "Строевско шосе" 3

тел./факс 032/ 953 666

GSM 0885/ 808 003

Варна 9000, кв. "Владиславово"

бул. "Атанас Москов" 13

тел.: 052/ 504 514

GSM 0885/ 808 004

София 2227, кв."Божурище"

бул. "Европа" 180, склад 33

тел.: 02/ 925 22 37

GSM 0889/ 334 692

Проверил: Р.Ч./16.10.2016г.



## H. AVERTISMENTE

1. Scoateți produsul din vehiculul în termen de 30 s
2. NU conectați ambele borne. Poate fi periculos!
3. NU demontați unitatea principală. Poate fi periculos!



Fiți atent întotdeauna când folosiți dispozitivul

Acest aparat nu este destinat utilizării de către copii sau persoane infirme fără supraveghere.



Nu utilizați ca o jucărie.



Nu permiteți ca aparatul să se ude.



Nu scufundați aparatul în apă



Nu utilizați aparatul în atmosfere explozive și în prezența lichidelor inflamabile, a gazelor sau a prafului.



Nu modificați și nu demontați dispozitivul de aprindere externă. Numai un tehnician autorizat poate repara acest aparat.



Nu expuneți aparatul la căldură.

Nu depozitați în locuri în care temperatura poate depăși 70°C



Se încarcă numai la temperaturi cuprinse între - 20°C - 60°C



Încărcați folosind încărcătorul furnizat împreună cu aparatul



În condiții extreme, poate provoca scurgeri de la baterie. Ștergeți cu grijă lichidul folosind o cârpă și evitați contactul cu pielea atunci când observați lichid pe baterie. În cazul contactului cu pielea sau ochii, clătiți imediat cu apă curată și cautați îngrijire medicală



La finalul duratei de viață utilă, eliminați dispozitivul cu grija pentru mediul înconjurător.



e-mail: [info@valerii.com](mailto:info@valerii.com) [www.valerii.com](http://www.valerii.com)

Сервиз: тел. 02/ 942 34 70 (национален)

Централен офис: София 1517

кв. "Сухата река" бул. "Ботевградско шосе" 44

тел.: 02/ 942 34 00, факс.: 02/ 945 4634

GSM 0889/ 444 991

Пловдив, с.Труд 4199

ул. "Строевско шосе" 3

тел./факс 032/ 953 666

GSM 0885/ 808 003

Варна 9000, кв. "Владиславово"

бул. "Атанас Москов" 13

тел.: 052/ 504 514

GSM 0885/ 808 004

София 2227, кв."Божурище"

бул. "Европа" 180, склад 33

тел.: 02/ 925 22 37

GSM 0889/ 334 692

Проверил: Р.Ч./16.10.2016г.



## I. ИНФОРМАЦИИ DE GARANȚIE:

- 1 Pentru acest produs, oferim garanție limitată împotriva oricăror defecte de materiale și de manoperă pe o perioadă de 36 luni de la data achiziționării de către utilizatorul final. Condițiile de garanție sunt după cum urmează:
- 2 Garanția este valabilă numai la prezentarea chitanței originale (de la comercianții angrosis/cu amănuntul) de către cumpărătorul inițial produsul care are nevoie de reparații sau înlocuire
- 3 Garanția nu este valabilă în cazul în care data cumpărării a fost eliminată sau ștersă
- 4 Garanția nu acoperă deteriorarea sau defectarea produsului din cauza uzurii normale, abuzul fizic, instalarea necorespunzătoare, utilizarea improprie, modificarea sau repararea de către terțe părți neautorizate.
5. Nu ne asumăm nici o responsabilitate pentru orice daune suferite în timpul transportului sau din motive de forță majoră.
6. Nu ne asumăm nici o responsabilitate pentru orice daune accidentale sau consecutive care decurg din utilizarea sau utilizarea greșită a produsului.
7. Toate cererile de garanție sunt limitate la repararea sau înlocuirea produsului defect și numai la discreția noastră.
- 8 În cazul reparării sau înlocuirii produsului, garanția va acoperi restul perioadei inițiale. Repararea sau înlocuirea poate include utilizarea a unităților reluate, care au o funcție echivalentă. Piese sau produse schimbate devin proprietatea noastră.
- 9 Componente - consumabile nu se acoperă de garanție.

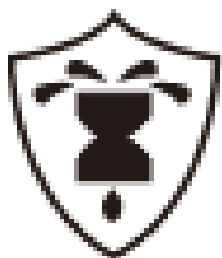

Protecție împotriva supraîncărcării și suprasarcinii

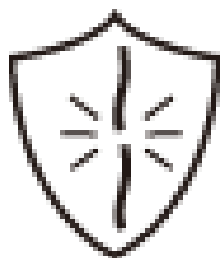

Protecție cu siguranță



Protecția împotriva inversării fișei

Standard aplicat: GB/ T 18287 - 2000



e-mail: [info@valerii.com](mailto:info@valerii.com) [www.valerii.com](http://www.valerii.com)

Сервиз: тел. 02/ 942 34 70 (национален)

Централен офис: София 1517

кв. "Сухата река" бул. "Ботевградско шосе" 44

тел.: 02/ 942 34 00, факс.: 02/ 945 4634

GSM 0889/ 444 991

Пловдив, с.Труд 4199

ул. "Строевско шосе" 3

тел./факс 032/ 953 666

GSM 0885/ 808 003

Варна 9000, кв. "Владиславово"

бул. "Атанас Москов" 13

тел.: 052/ 504 514

GSM 0885/ 808 004

София 2227, кв."Божурище"

бул. "Европа" 180, склад 33

тел.: 02/ 925 22 37

GSM 0889/ 334 692

Проверил: Р.Ч./16.10.2016г.





## Зарядно стартерно устройство за акумутори PREMIUM-ND

### РЪКОВОДСТВО ЗА ПОТРЕБИТЕЛЯ

Благодарим Ви, че избрахте нашия външен източник за запалване!  
Винаги спазвайте основните мерки за безопасност, когато използвате електрически уреди. Прочетете всички инструкции внимателно, моля, запазете това ръководство за лесна справка.

Модел: **0503BCINVERTER**

#### Г. ОБЩ ИЗГЛЕД НА ПРОДУКТА:

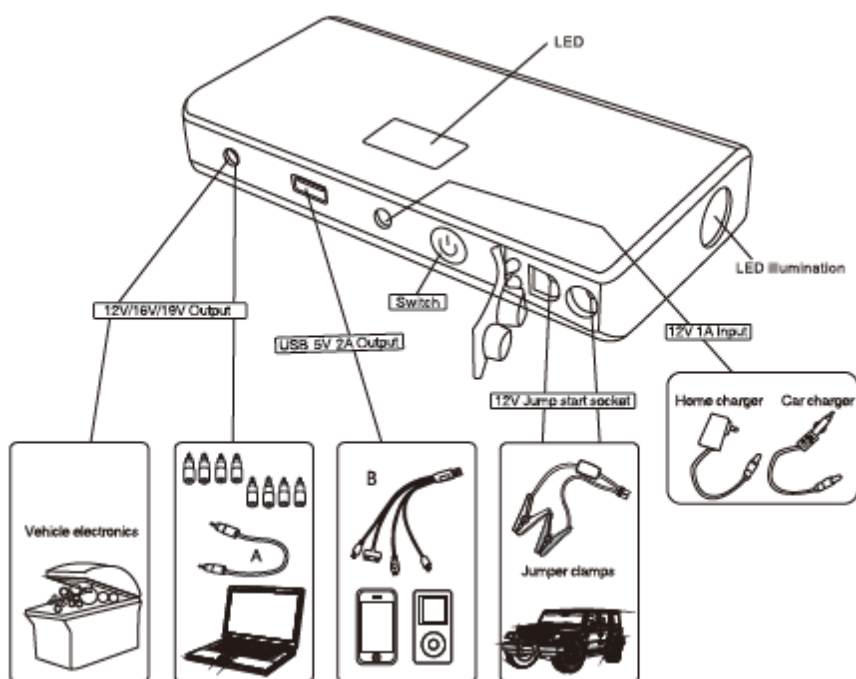

e-mail: [info@valerii.com](mailto:info@valerii.com) [www.valerii.com](http://www.valerii.com)  
Сервиз: тел. 02/ 942 34 70 (национален)

Централен офис: София 1517  
кв. "Сухата река" бул. "Ботевградско шосе" 44  
тел.: 02/ 942 34 00, факс.: 02/ 945 4634  
GSM 0889/ 444 991

Пловдив, с.Труд 4199  
ул. "Строевско шосе" 3  
тел./факс 032/ 953 666  
GSM 0885/ 808 003

Варна 9000, кв. "Владиславово"  
бул. "Атанас Москов" 13  
тел.: 052/ 504 514  
GSM 0885/ 808 004

София 2227, кв."Божурище"  
бул. "Европа" 180, склад 33  
тел.: 02/ 925 22 37  
GSM 0889/ 334 692

Проверил: Р.Ч./16.10.2016г.



## Г. ИНСТРУКЦИИ ЗА ЕКСПЛОАТАЦИЯ

### Индикатор

Натиснете прекъсвача, за да проверите нивото на външния източник за запалване

Инструкции за зареждане на Външен Източник на Запалване:

3. Включете домашния адаптер към универсален контакт
4. Свържете входния порт 12 V 1 A на Външен Източник на Запалване към другия край на домашния адаптер.

Или

1. Включете автомобилния адаптер в гнездото на запалката.
2. Свържете входния порт 12 V 1 A на Външен Източник на Запалване към другия край на автомобилния адаптер.

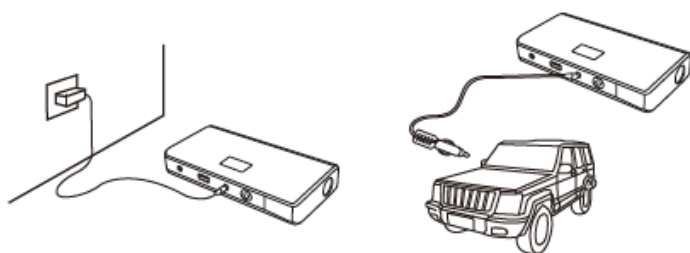

Инструкция за автомобилния външен източник за запалване 12 V:

8. Уверете се, че оставащата мощност е не по-малко от 70
9. Свържете ЧЕРВЕНАТА скоба към положителната клема на акумулаторната батерия и свържете ЧЕРНАТА скоба към отрицателната клема на автомобилния акумулатор.
10. Включете кабела за запалване на автомобила от външен източник към гнездото на външния източник за запалване.



e-mail: [info@valerii.com](mailto:info@valerii.com) [www.valerii.com](http://www.valerii.com)  
Сервиз: тел. 02/ 942 34 70 (национален)

Централен офис: София 1517  
кв. "Сухата река" бул. "Ботевградско шосе" 44  
тел.: 02/ 942 34 00, факс.: 02/ 945 4634  
GSM 0889/ 444 991

Пловдив, с.Труд 4199  
ул. "Строевско шосе" 3  
тел./факс 032/ 953 666  
GSM 0885/ 808 003

Варна 9000, кв. "Владиславово"  
бул. "Атанас Москов" 13  
тел.: 052/ 504 514  
GSM 0885/ 808 004

София 2227, кв."Божурище"  
бул. "Европа" 180, склад 33  
тел.: 02/ 925 22 37  
GSM 0889/ 334 692

Проверил: Р.Ч./16.10.2016г.



11. Запалете автомобила.
12. Когато автомобила е запален, отстранете кабела за външно запалване от устройството и разкачете клемите на автомобилния акумулатор в рамките на 30 секунди.
13. Оставете двигателя на автомобила да работи



Инструкция за зареждане на мобилен телефон или таблет:

4. Включете захранващия кабел В към външен USB порт 5 V 2 A.
5. Изберете съответния накрайник за Вашия мобилен телефон или таблет и го свържете към телефона или таблета, външното устройство за запалване може автоматично да идентифицира и зареди електронното устройство.
6. Натиснете прекъсвача за зареждане. Когато устройството се зарежда, индикаторите се включват.

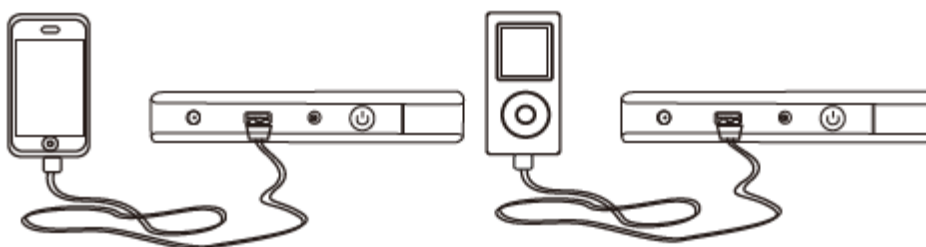

Зареждане/ източник на захранване за 16 V/ 19 V лаптоп:

1. Включете захранващия кабел А към изходен порт 12 V/ 16 V/ 19 V.
2. Изберете съответния накрайник за Вашия лаптоп и го свържете към захранващия кабел А.
3. Натиснете прекъсвача и изберете правилното изходно напрежение за зареждане на лаптопа.

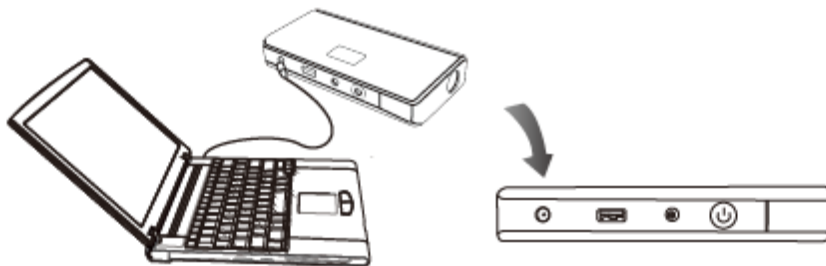



Захранване за 12 V автомобилни електронни устройства:

1. Свържете захранващия кабел А към изходен порт 12 V/ 16 V/ 19 V.
2. Свържете опционалния захранващ кабел към 12 V автомобилна електроника.
3. Натиснете прекъсвача и изберете правилното изходно напрежение и мощността, захранваща електрониката.

LED мигаща светлина

Натиснете и задръжте прекъсвача за 3 секунди, за да стартирате мигащата LED светлина.

Ако натиснете леко, LED светлината има 4 режима, които се редуват (нормален, стробоскопична светлина, SOS, изключено).

## Н. СПИСЪК ЧАСТИ:

№	Име на част	Количество	№	Име на част	Количество
1	Основен модул	1	5	Домашен адаптер	1
2	Захранващ кабел А	1	6	Автомобилен адаптер	1
3	Накрайници за лаптоп	8	7	Ръководство на потребителя	1
4	Кабел за запалване със скоби	1	8	USB кабел	1

## І. ТЕХНИЧЕСКА СПЕЦИФИКАЦИЯ:

Размери: 160\*75\*28 mm

Тегло: 430 g

Изход: 5 V ~ 2 A, (12 V, 16 V, 19 V) / 3.5 A

Вход: 12 V = 1 A

Пълно време за зареждане: 5 часа

Стартов ток: 200 A

Пиков ток: 400 A

Експлоатационна температура: -20°C - 60°C

## Ј. ЧЕСТО ЗАДАВАНИ ВЪПРОСИ:

Q. Как да изключа този уред?

A. Този уред ще се изключи автоматично, когато няма товар или зареждането е завършено

Q. Колко пъти мога да зареда мобилния си телефон с този уред?

A. 6 пъти за Iphone 4 мобилен телефон.



e-mail: [info@valerii.com](mailto:info@valerii.com) [www.valerii.com](http://www.valerii.com)

Сервиз: тел. 02/ 942 34 70 (национален)

Централен офис: София 1517

кв. "Сухата река" бул. "Ботевградско шосе" 44

тел.: 02/ 942 34 00, факс.: 02/ 945 4634

GSM 0889/ 444 991

Пловдив, с.Труд 4199

ул. "Строевско шосе" 3

тел./факс 032/ 953 666

GSM 0885/ 808 003

Варна 9000, кв. "Владиславово"

бул. "Атанас Москов" 13

тел.: 052/ 504 514

GSM 0885/ 808 004

София 2227, кв."Божурище"

бул. "Европа" 180, склад 33

тел.: 02/ 925 22 37

GSM 0889/ 334 692



Q. Колко време отнема на този уред да зареди моя телефон напълно?

A. Приблизително 1 час

Q. Колко време този уред може да захранва лаптоп при пълен заряд?

A. 2-3 часа.

Q. Колко пъти този уред може да запали автомобила ми при пълен заряд?

A. Приблизително 20 пъти.

Q. Колко дълго се запазва заряда на този уред?

A. 3-6 месеца, въпреки, че Ви съветваме да го презареждате на всеки 2 месеца.

## К. ОТСТРАНЯВАНЕ НА НЕИЗПРАВНОСТИ:

Проявление	Причина	Отстраняване
Външният източник на запалване не е напълно зареден, а неговия LED индикатор показва 99	Действителната остатъчна мощност е около 60%, но се изобразява 99%	Изключете адаптера и го включете отново
Няма реакция при натискане на прекъсвача.	Активирана е минимално напреженовата защитата на външния източник.	Включете адаптера във входен порт 12 V 1 A, за да активирате.
Външният източник е леко нагрял докато зарежда лаптоп.	Токът на зареждане е висок (3.5 A)	Отстранете батерията от лаптопа или заредете лаптопа след 5 минути почивка.

## Г. ТОКСИЧНИ И ВРЕДНИ ВЕЩЕСТВА:

Състав и количество на токсични и вредни вещества във външния източник за запалване

Pb	Hg	Cd	Cr(VI)	PBB	PBDE
0	0	0	0	0	0

0: Означава, че съдържанието на вредни вещества във всички хомогенни материали под MCV границата, определена в стандарт 2002/05/EC (RoHS)



e-mail: [info@valerii.com](mailto:info@valerii.com) [www.valerii.com](http://www.valerii.com)

Сервиз: тел. 02/ 942 34 70 (национален)

Централен офис: София 1517

кв. "Сухата река" бул. "Ботевградско шосе" 44

тел.: 02/ 942 34 00, факс.: 02/ 945 4634

GSM 0889/ 444 991

Пловдив, с.Труд 4199

ул. "Строевско шосе" 3

тел./факс 032/ 953 666

GSM 0885/ 808 003

Варна 9000, кв. "Владиславово"

бул. "Атанас Москов" 13

тел.: 052/ 504 514

GSM 0885/ 808 004

София 2227, кв."Божурище"

бул. "Европа" 180, склад 33

тел.: 02/ 925 22 37

GSM 0889/ 334 692



## Н. Предупреждения:

1. **ОТСТРАНЯВАЙТЕ** продукта от автомобила в рамките на 30 s
2. **НЕ** свързвайте двете скоби. Това може да бъде опасно!
3. **НЕ** разглобявайте основния модул. Това може да бъде опасно!



Винаги внимавайте при използване на уреда



Този уред не е предназначен за използване от малки деца или лица с увреждания без надзор.



Не използвайте като играчка.



Не допускайте уреда да се намокри.



Не потапяйте уреда във вода



Не работете с уреда в експлозивни атмосфери, както и при наличието на запалими течности, газове или прах.



Не променяйте или не разглобявайте Външното устройство за запалване. Само оторизиран техник може да ремонтира този уред.



Не излагайте уреда на топлина.



Не съхранявайте на места, където температурата може да надвиши 70°C.



Зареждайте само при температура на околната среда между - 20°C - 60°C.



Зареждайте само като използвате зарядното устройство, доставено с уреда



В екстремни условия, може да възникне теч от батерията. Внимателно избършете течността като използвате кърпа и избягвайте контакт с кожата, когато забележите течност по батерията. В случай на контакт с кожата или очите, изплакнете незабавно с чиста вода и потърсете медицинска помощ

В края на полезния му живот, изхвърлете уреда с грижа за околната среда.



e-mail: [info@valerii.com](mailto:info@valerii.com) [www.valerii.com](http://www.valerii.com)

Сервиз: тел. 02/ 942 34 70 (национален)

Централен офис: София 1517

кв. "Сухата река" бул. "Ботевградско шосе" 44

тел.: 02/ 942 34 00, факс.: 02/ 945 4634

GSM 0889/ 444 991

Пловдив, с.Труд 4199

ул. "Строевско шосе" 3

тел./факс 032/ 953 666

GSM 0885/ 808 003

Варна 9000, кв. "Владиславово"

бул. "Атанас Москов" 13

тел.: 052/ 504 514

GSM 0885/ 808 004

София 2227, кв."Божурище"

бул. "Европа" 180, склад 33

тел.: 02/ 925 22 37

GSM 0889/ 334 692

Проверил: Р.Ч./16.10.2016г.



## I. ГАРАНЦИОННА ИНФОРМАЦИЯ:

1. За този продукт предлагаме ограничена гаранция срещу всички дефекти в материалите и изработката за период от 36 месеца от датата на покупката от крайния потребител. Условието на гаранцията са както следва:
2. Гаранцията е валидна само при представяне на оригинална квитанция (от търговец на едро/ дребно) от оригиналния купувач заедно с продукта, който се нуждае от ремонт или смяна.
3. Гаранцията е невалидна ако означението за датата на покупката е премахнато или изтрито
4. Гаранцията не покрива щети или повреда на продукта в резултат на нормално износване, физическо насилие, неправилно инсталиране, неправилно използване, промяна или ремонт от неоторизирани трети страни.
5. Не поемаме отговорност за всички щети, възникнали по време на транспортиране или в резултат на форс мажорни обстоятелства.
6. Не поемаме отговорност за никакви случайни или последващи щети, възникнали от използването или неправилното използване на продукта.
7. Всички гаранционни претенции се ограничават до ремонт или смяна на дефектен продукт и само до нашата преценка.
8. Ако ремонтираме или сменим продукт, продуктът ще има гаранция, покриваща остатъка от първоначалния период. Ремонтът или смяната на могат да включват използване на възобновени модули, които имат еквивалентна функция. Сменените части или продукти стават наша собственост.
9. Компонентите - консумативи не са покрити от гаранцията.

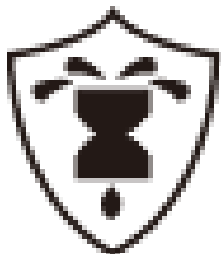

Защита срещу свръх зареждане и свръх разряд

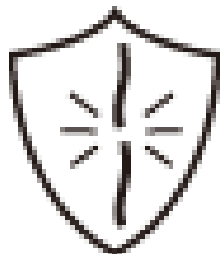

Защита с предпазител



Защита срещу обръщане на щепсела

Приложен стандарт: GB/ T 18287 - 2000



e-mail: [info@valerii.com](mailto:info@valerii.com) [www.valerii.com](http://www.valerii.com)

Сервиз: тел. 02/ 942 34 70 (национален)

Централен офис: София 1517

кв. "Сухата река" бул. "Ботевградско шосе" 44

тел.: 02/ 942 34 00, факс.: 02/ 945 4634

GSM 0889/ 444 991

Пловдив, с.Труд 4199

ул. "Строевско шосе" 3

тел./факс 032/ 953 666

GSM 0885/ 808 003

Варна 9000, кв. "Владиславово"

бул. "Атанас Москов" 13

тел.: 052/ 504 514

GSM 0885/ 808 004

София 2227, кв."Божурище"

бул. "Европа" 180, склад 33

тел.: 02/ 925 22 37

GSM 0889/ 334 692

Проверил: Р.Ч./16.10.2016г.